

 **AUTOMATION STUDIO™ P6**
Professional Edition

WHAT'S NEW

P6



*Engineering
Synergy*

A Product of  **Famic Technologies Inc.**



An Entirely Redesigned Solution!

Once again, Automation Studio™ pushes the boundaries of innovation. The new version P6 widens the gap between other available system design software.

Automation Studio™ is already known for being the unique design & simulation solution covering all project/machine technologies including hydraulics, pneumatics, electrical, controls, HMI, and communications.

P6 makes available a wide array of innovation allowing organisations to release synergy amongst project's teams and to optimize every step of a product/project life cycle.

The result: increased productivity and reduced product time-to-market

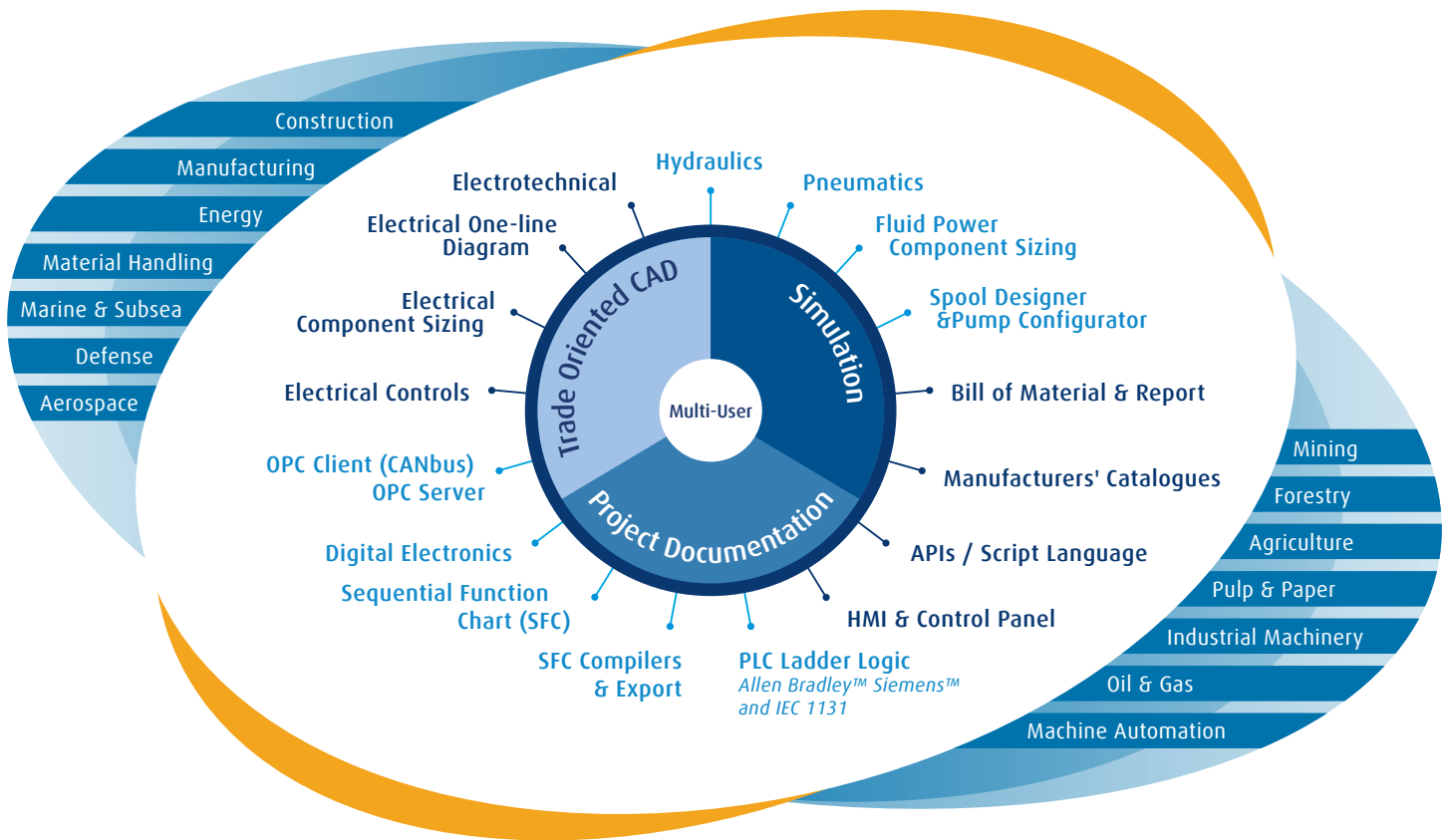

Innovative Ideas
Cutting-edge Technologies
Countless Possibilities



Collaborate for Better Efficiency!

A Collaborative Environment, Creator of Synergy

Automation Studio™ P6 is a multi-user environment. This allows you to perform collaborative work on a project through data sharing and synchronization between different users. Moreover, thanks to the Access Rights Manager, you can set access restrictions in reading, publishing, etc. Thus, you can safely share your projects, be it with customers, suppliers, and of course your colleagues.

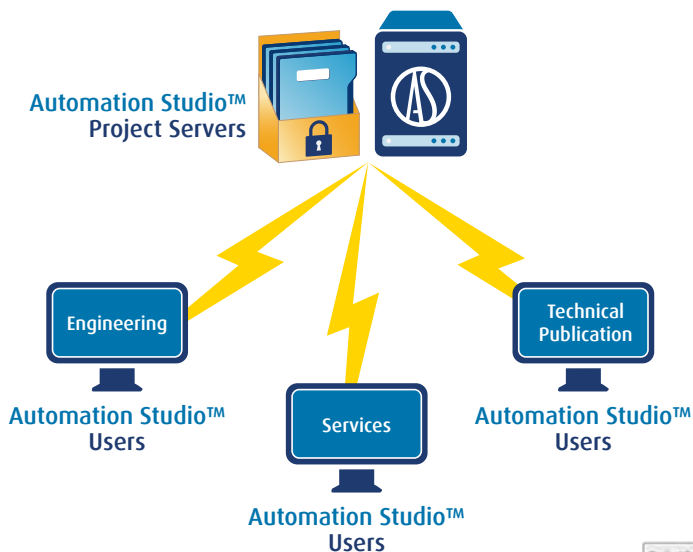

Configurable Project Explorer

Project Explorer is fully customizable. It allows you, dependent on your needs, to view the necessary and appropriate information. The new interface provides you with a global project overview and keeps you updated on the status of each one of its documents.

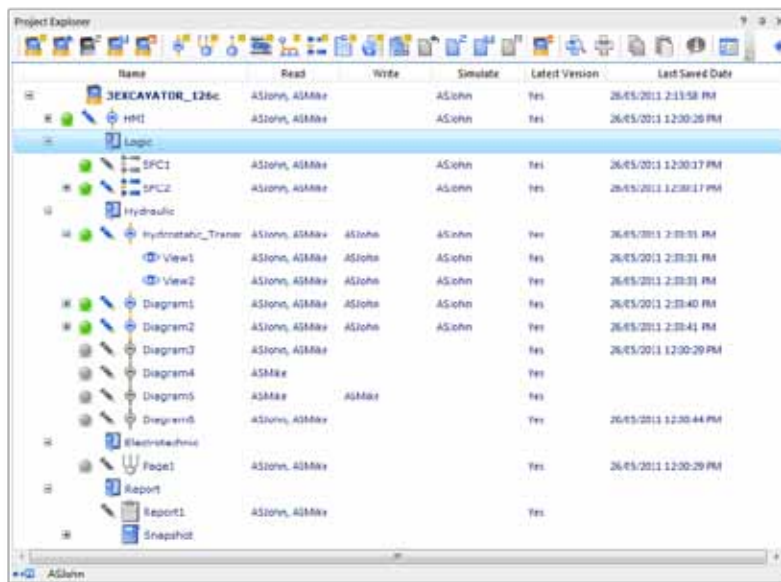

LAN/WAN Licenses Management

You can access Automation Studio™ License Server through a LAN or WAN connection. The server provides license usage logs and statistics.

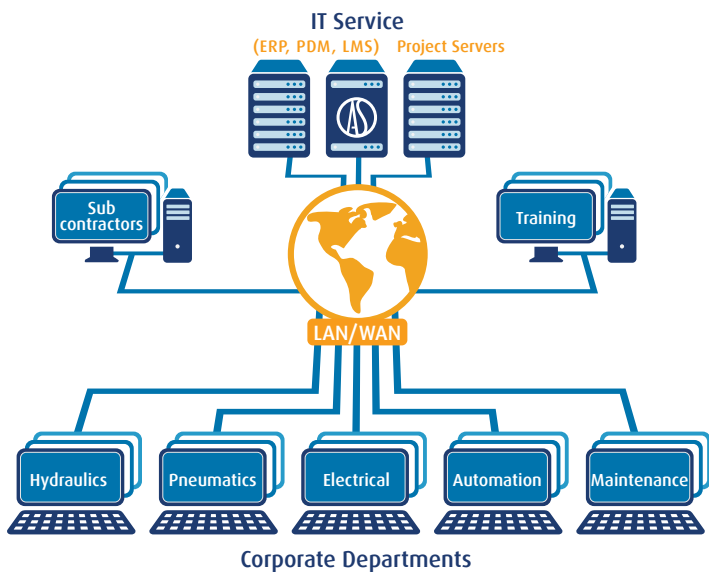



Enforce Company Wide Standards

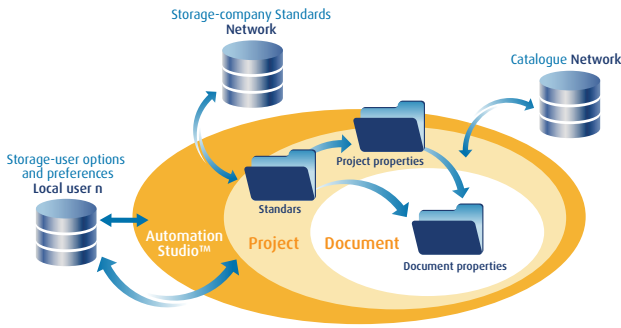

Manage your Standards

Standards can be defined at different hierarchical levels including: company, divisions, branches, projects, and documents. They can cover every aspects of a project for both technologies and documentation including: fluid, material, hoses, lines, wires, cables, connectors, font, colors, page layout, naming rules, components, title block, component representation during editing and simulation, etc.

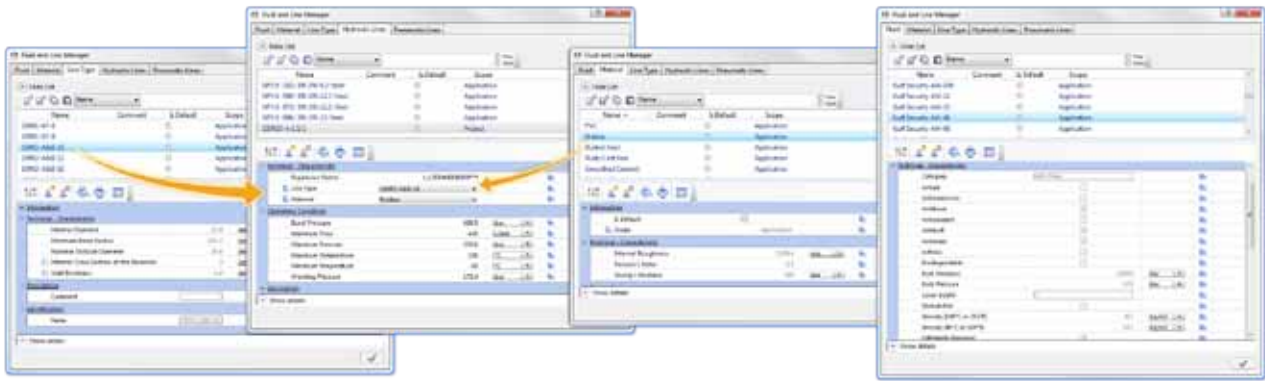

Enhanced Project Documentation

A rich set of functions for automatic report generation and flexible formatting is now available. Users can create their own templates for any type of document or report: Title Block, BOM, Wire List, Purchase Orders, etc.

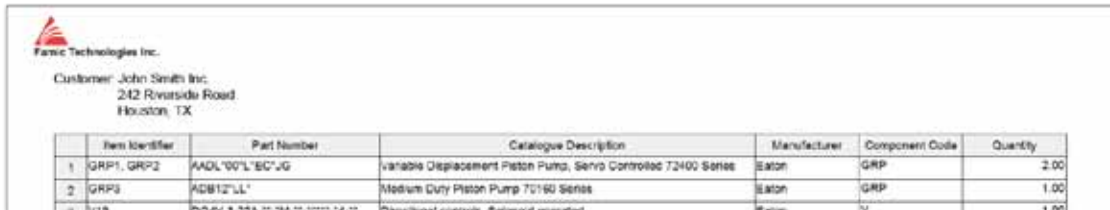

Automate your Workflow by Using the Appropriate Templates

You can define a specific standard for each department using Automation Studio™. Furthermore, applying the appropriate standards allows you to automate many activities in your workflow. For instance, engineering drawings can be reused by a Technical Publications department to automatically convert them to appropriate presentation formats without having the need to use specialized authoring tools or doing tedious and time consuming manual conversion.

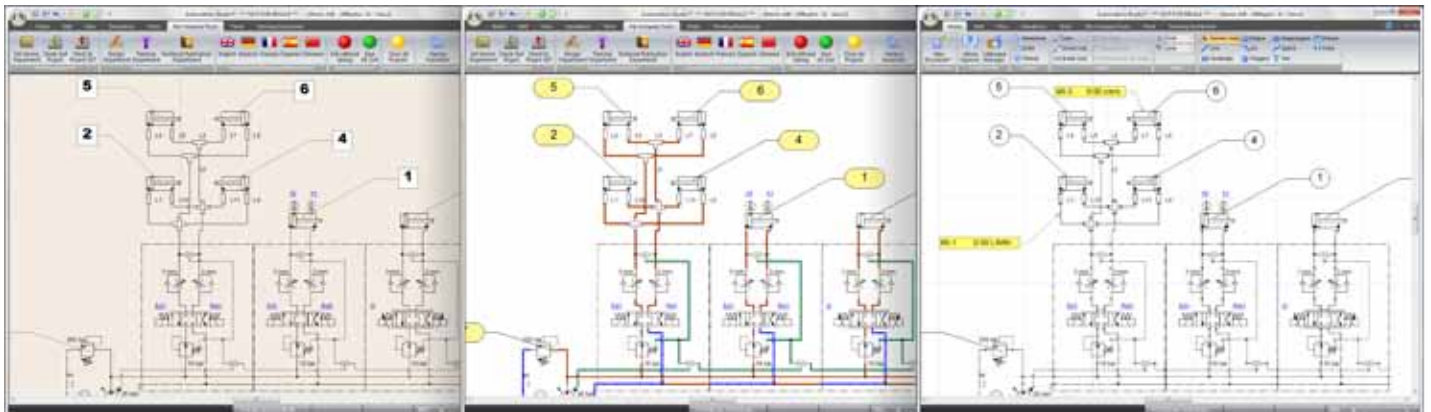



Configure your Lines

Fluid and line configurator allows you to configure the lines based on circuit, installation, function, material, types, etc. Line appearance can be configured for both editing and simulation. Furthermore, during simulation, the appearance can be defined as a function of threshold levels of either flow or pressure.

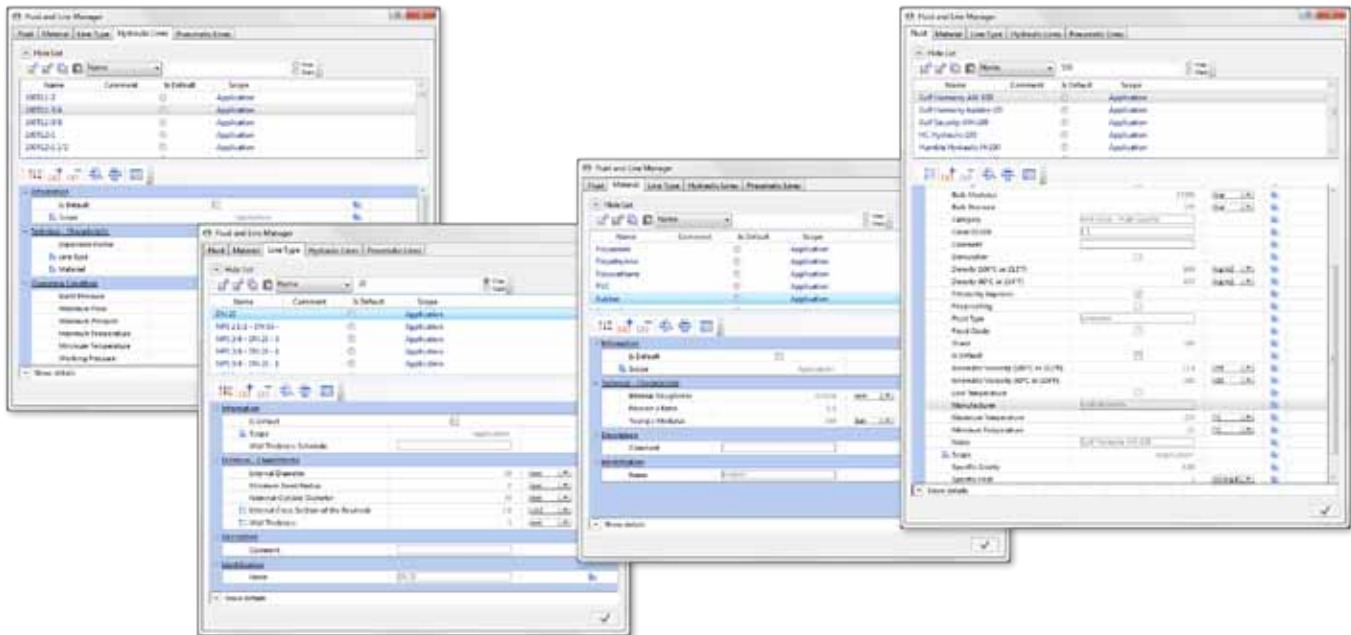

Customize your Workspace

A Modern User Interface

P6 user interface optimizes your screen's workspace. It implements contemporary concepts such as configurable ribbon bars, retractable, floating, and docked dialogues. This improved environment allows for data entry to be automatically validated, advanced undo/redo features, and harmonization of properties dialogs.



Make P6 an Integral Part of your Corporate Applications

Thanks to the Application Programming Interfaces (API) and scripting language, Automation Studio™ users now have access to a new level of application integration:

- Access to many Automation Studio™ functions normally available through menus;
- Communicate with your corporate applications such as: PDM, ERP, 3DCAD, and others;
- Overload standards functions;
- Customize the user interface;
- Develop new applications by reusing Automation Studio™ functions.

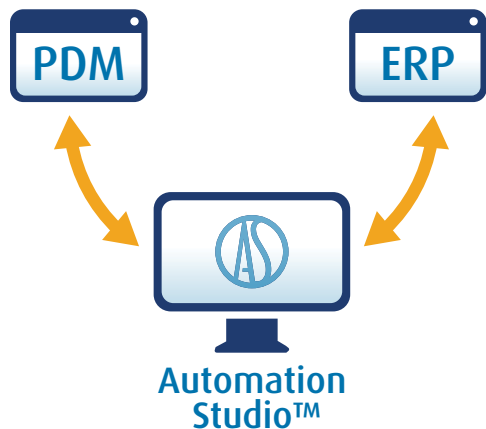



Improved Set of Support Tools

Event Log Manager

The Message Explorer manages events, warnings and errors also provides advanced filtering capabilities.

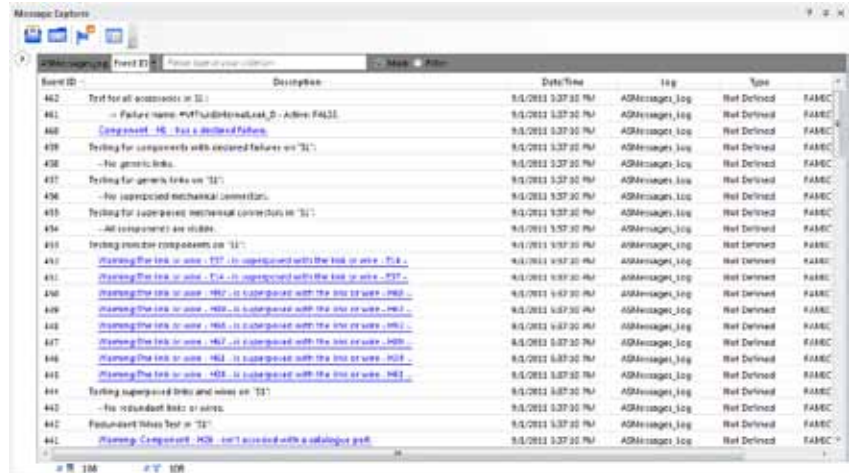

Configurable Tooltips

Detailed information is displayed when hovering over an object on the screen. Hence, you now have easily access to the pertinent component properties.

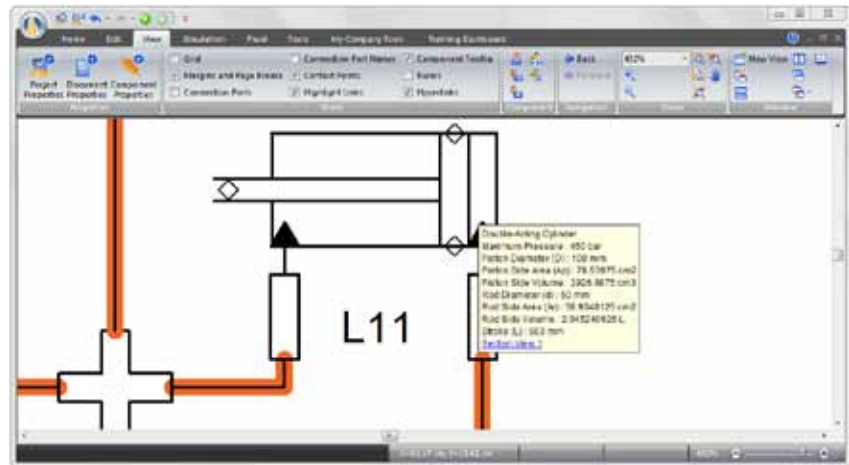

Multilingual Projects

A major advantage in today's competitive markets is to provide customers worldwide with product documentation in their own language. With P6, users don't need to recreate their projects for each language supported. A project integrated translation database manages all information required to switch the project from one language to another including texts, pictures, hyperlinks, audios, and videos.

The user simply chooses the active language and Automation Studio™ will automatically replace all corresponding information in the project with the equivalent ones found in the translation database. This new feature facilitates the transfer of your projects to your clients, colleagues or partners abroad.

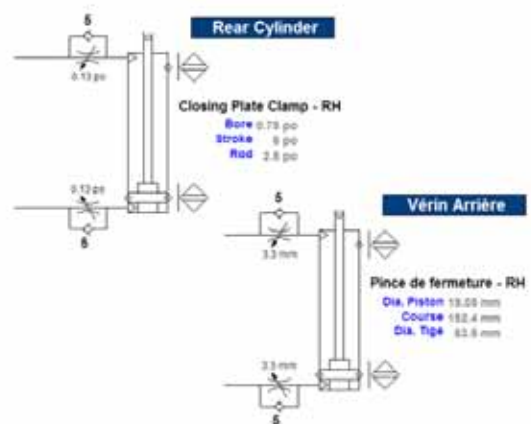
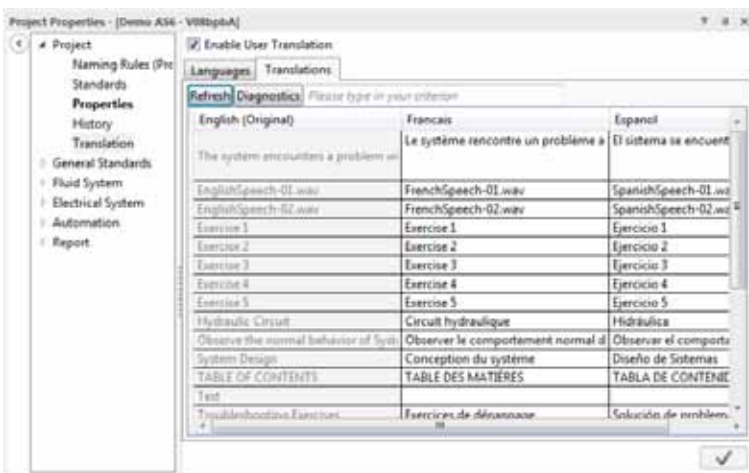



Hydraulics and Pneumatics

Redesigned Libraries

The generic component libraries have been redesigned. The components have been grouped by function in order to facilitate navigation.

Additional CAD drawing objects have been added.

Diagnostic Tools

P6 provides extensive diagnostic tools allowing for detection of inconsistencies or errors such as free connectors, redundant or overlapping lines, non-compliance with ISO standards, etc.

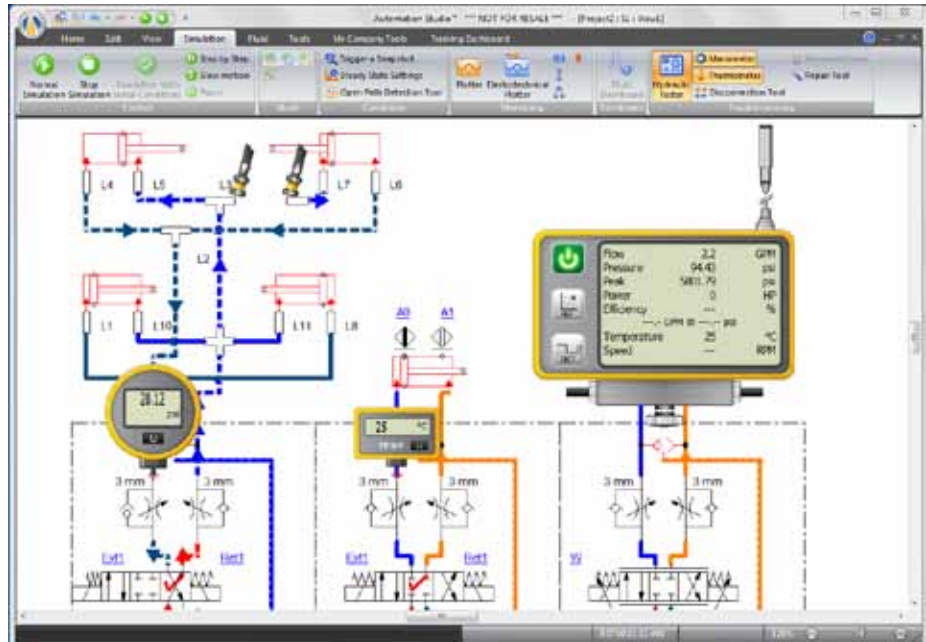

Simulation Improvements

The simulation in P6 takes into consideration several additional phenomena and improves the evaluation of many existing ones including:

- Cavitation
- Vapour pressure of the oil
- Motor and pump volumetric and total efficiency
- Very high pressure system (>5000 Bar)

Accessory Management

The Accessory Manager provides users with a global view of all the accessories used in the project. Accessories and miscellaneous parts whether shown on schematics or not can easily be added to the project as well.

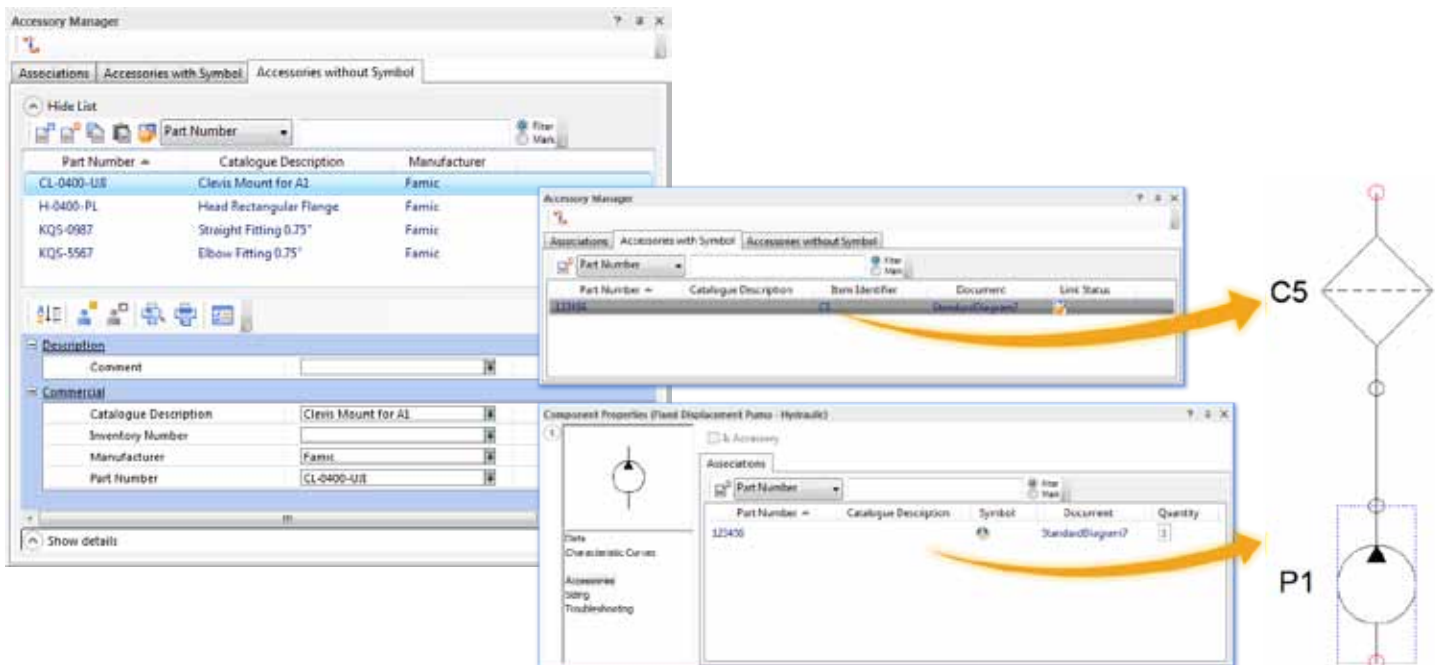



Electrotechnical

Enriched Libraries

P6 offers new electrical components including: splices, connectors and connection boxes, junctions and connections blocks, variable speed drives, and multipolar links to cover a wider scope of applications.

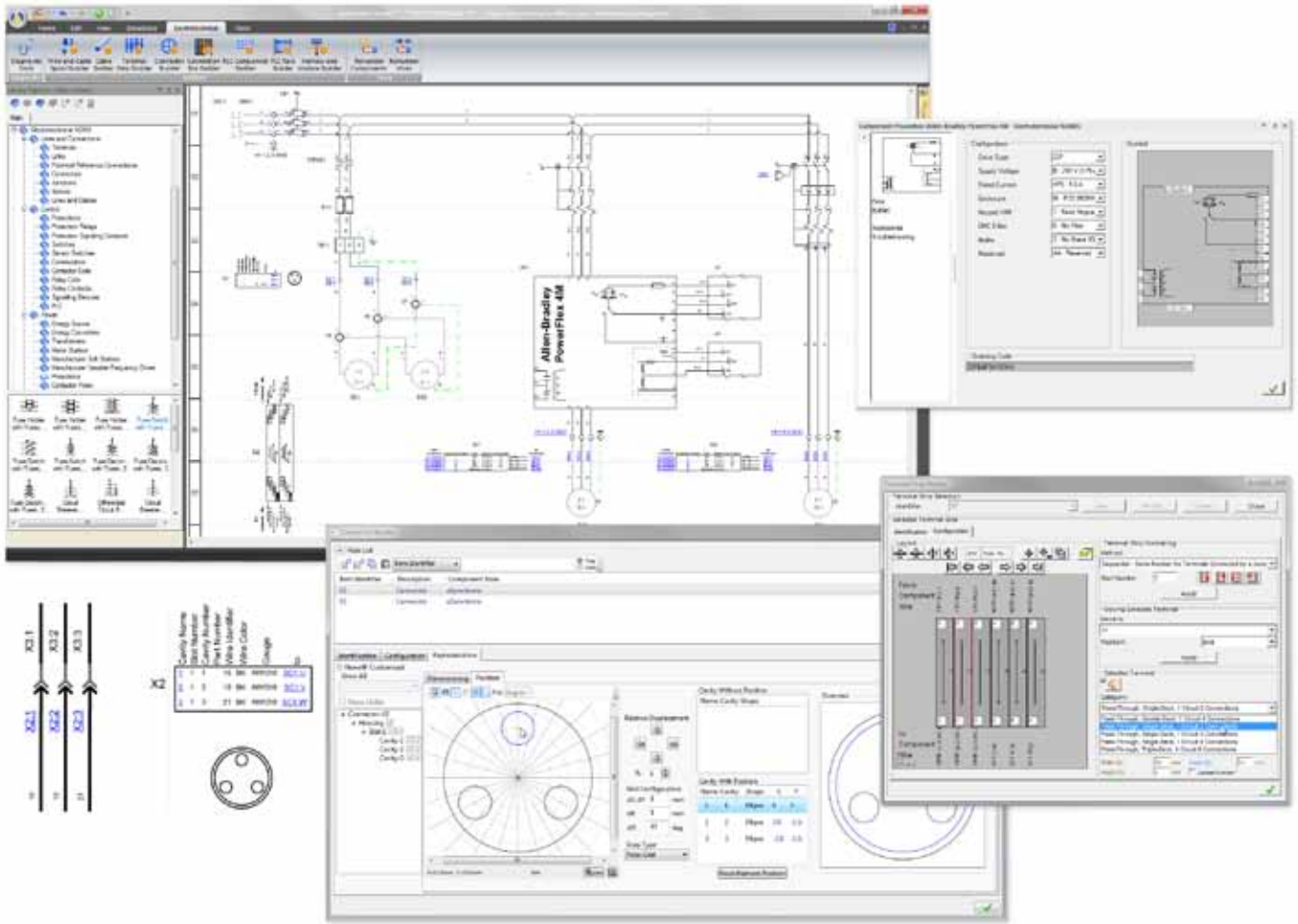

Wire & Cable Management

Wire and cable spools' management is now available. A dedicated configurator manages all spools related data including: materials, gauges, colors, patterns, detailed picture of cables, etc.

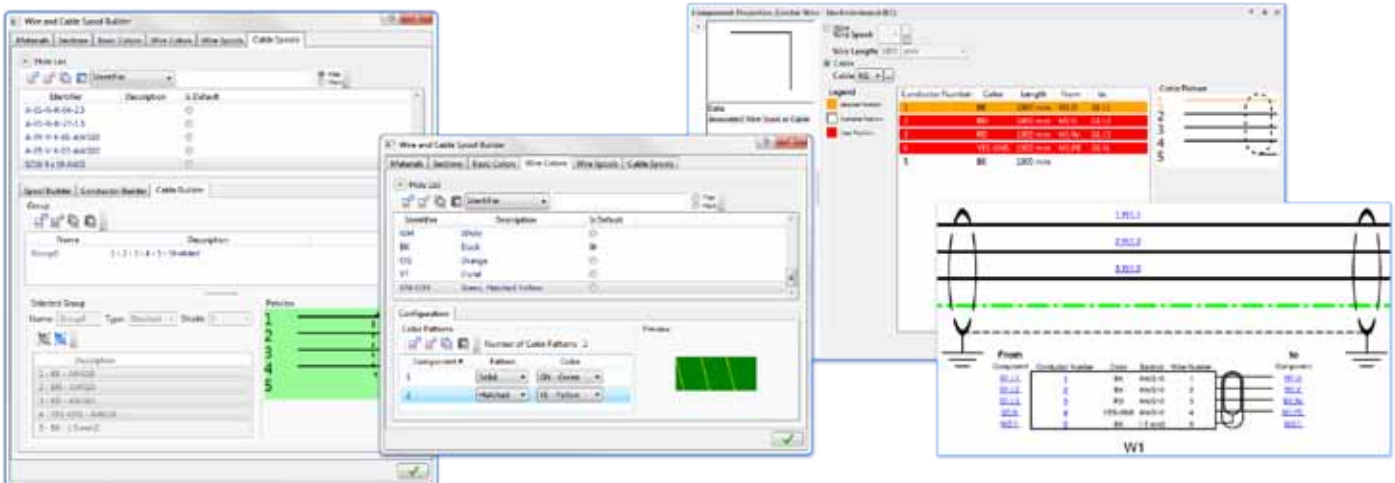



Improved Switches, Relays, and Protection Device Configurators

You can adjust contacts' spacing in groups and view the command on a single contact group or all groups. Moreover, you can add a cross-reference satellite by contact group and define a position matrix for switches. The image terminal has also been improved in order to be viewable on multiple lines. The wire identifier location can be configurable as well.

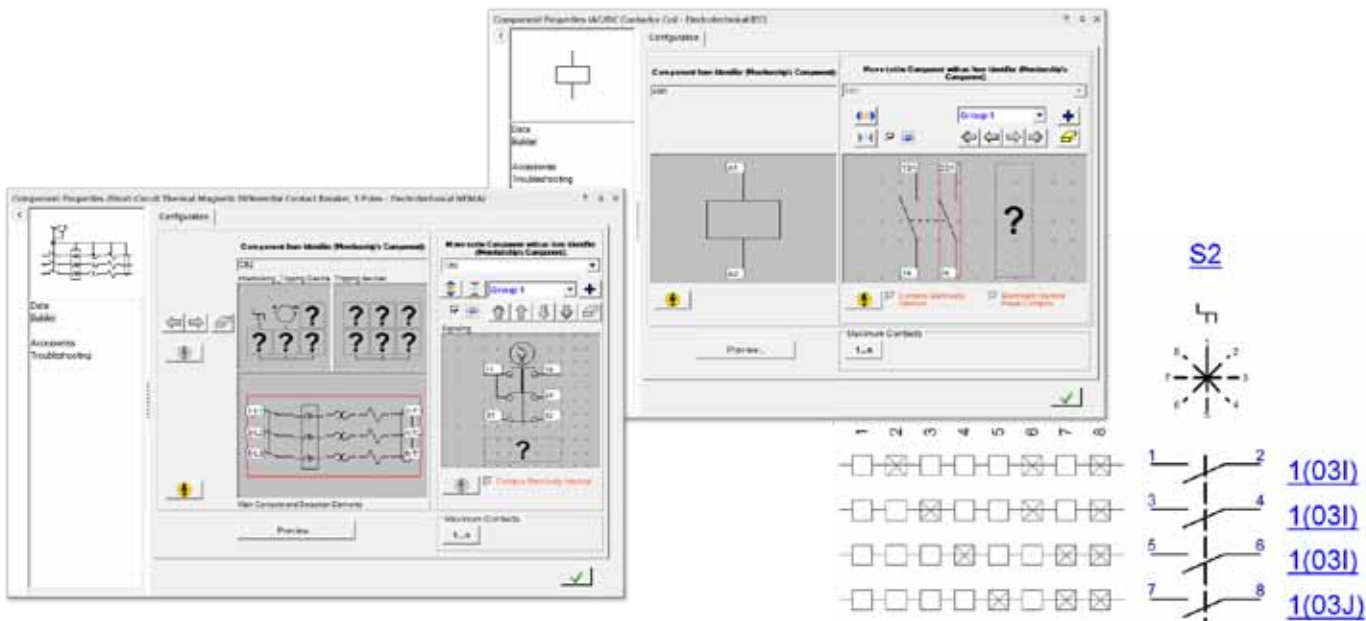

Connections Editors

P6 offers a dedicated editor so that the users can easily view and adapt the connection scheme showing components interconnections.

Improve your Troubleshooting Skills

The modelling of each hydraulic, pneumatic, and electrotechnical components integrates faults that can be triggered during the system simulation. A set of troubleshooting tools (multi-meter, hydraulic tester, pressure gages, and thermometer) can be used to diagnose and repair the problems. Users can quickly and easily perform "What-if" scenarios to resolve potential problems. It is possible to disconnect wires or lines to isolate parts of a circuit, perform measurements, and repair or replace components to solve suspected failures.

Over and above general training, this environment allows organizations to train their maintenance personnel and sharpen their skills relating to specific equipment by experimenting on the corresponding virtual system in a safe way. This will result in reduced equipment downtime and increased productivity.

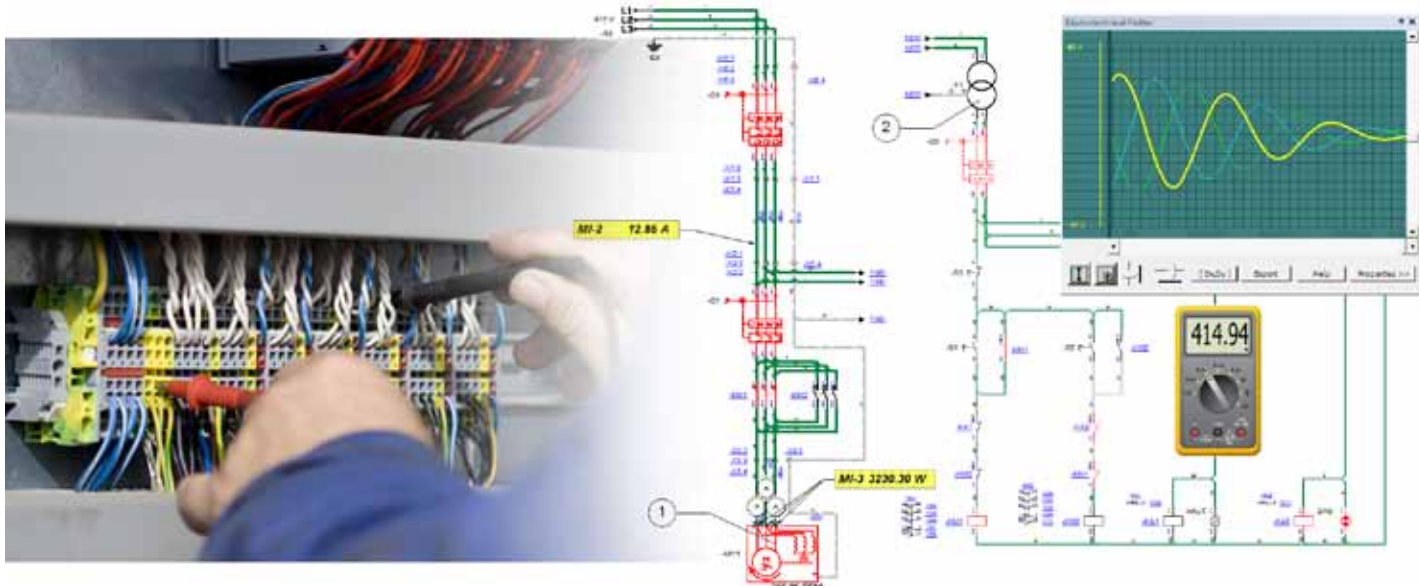



SCORM Compliant

If you are using a Learning Management System (LMS), P6 is SCORM compliant and allows you to easily integrated it into your LMS. By doing so, your online training contents will be greatly improved thanks to Automation Studio's realistic and interactive simulation.

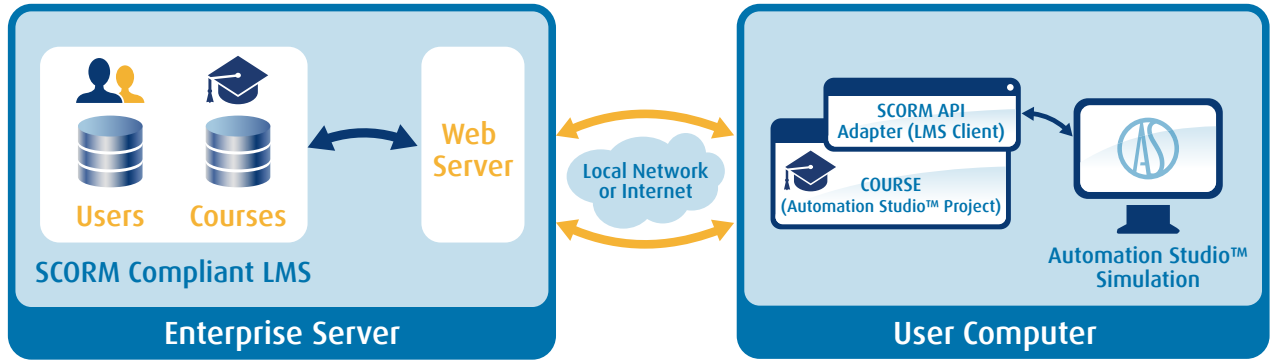

Full OPC Connectivity

OPC Server

P6 introduces its OPC Server, which implements the latest OPC UA V1.1 standard, providing improved interaction with external equipment. This interface allows you to read and write project variables organised by projects, schematics, components, and variables.

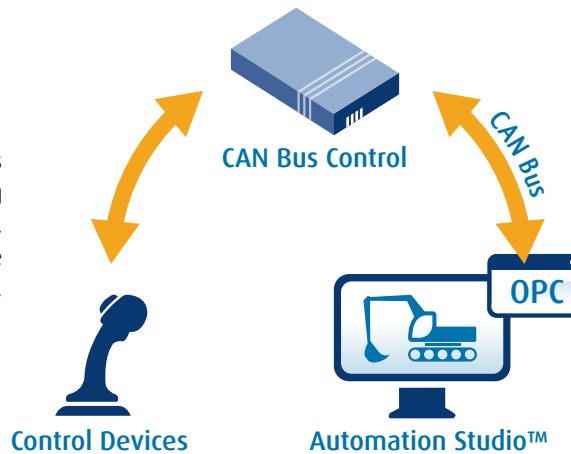

OPC Client

With its improved OPC Client, P6 supports OPC DA interfaces and V2.x V3.0 optimizing transfers and offering the ability to connect to multiple OPC Servers simultaneously. The software interface has been reviewed in order to improve the configuration and navigation process and to provide a dynamic display of the status of each configured item.

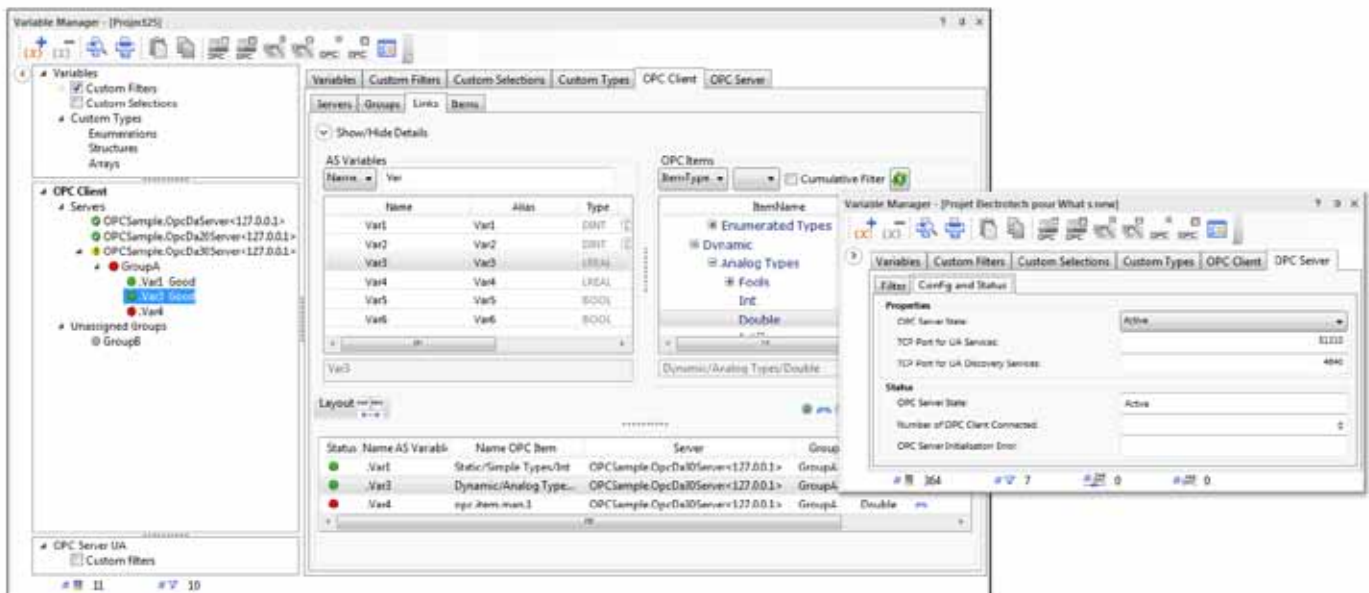



Variable Management

P6 offers a new fully customizable variable manager compliant to the IEC 61131-3 international standard. All data types are supported. A rich set of functions is available including: create and delete variables, automatic validation, display format, define aliases, define filters, import, export, etc.

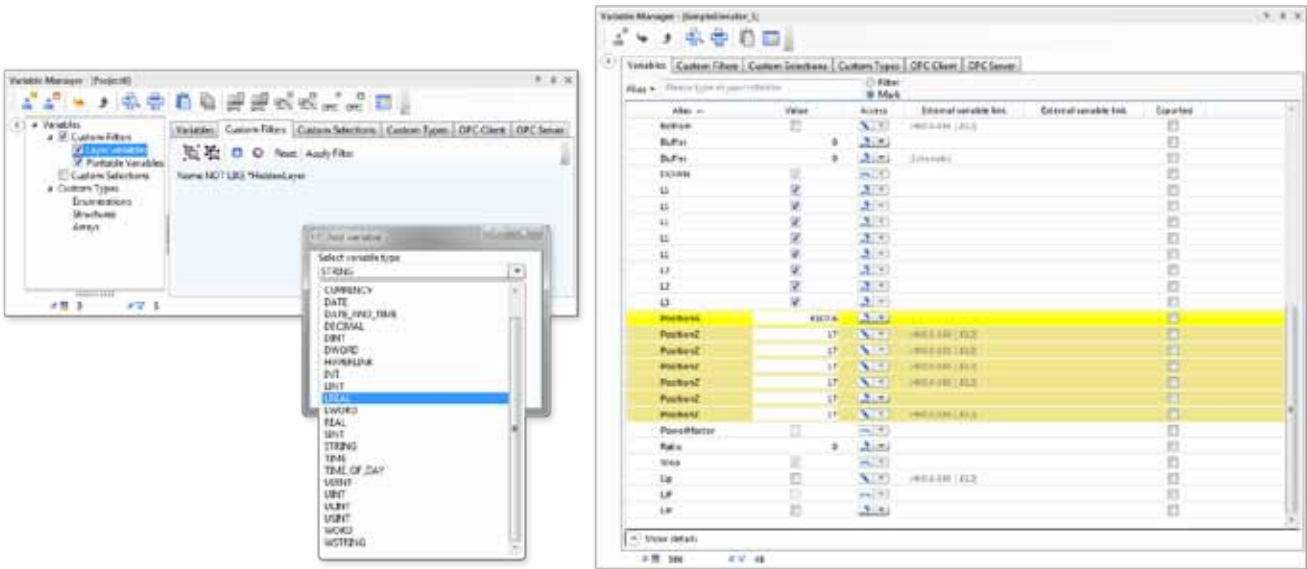

Manufacturers' Catalogues

Manufacturers' catalogues have been significantly improved! The product's validation status and 3D data along with product option configuration have been added to complete the range of information already at your fingertips.

New and updated manufacturer's catalogues are made available online on a regular basis.



Visit our website: www.automationstudio.com/catalog

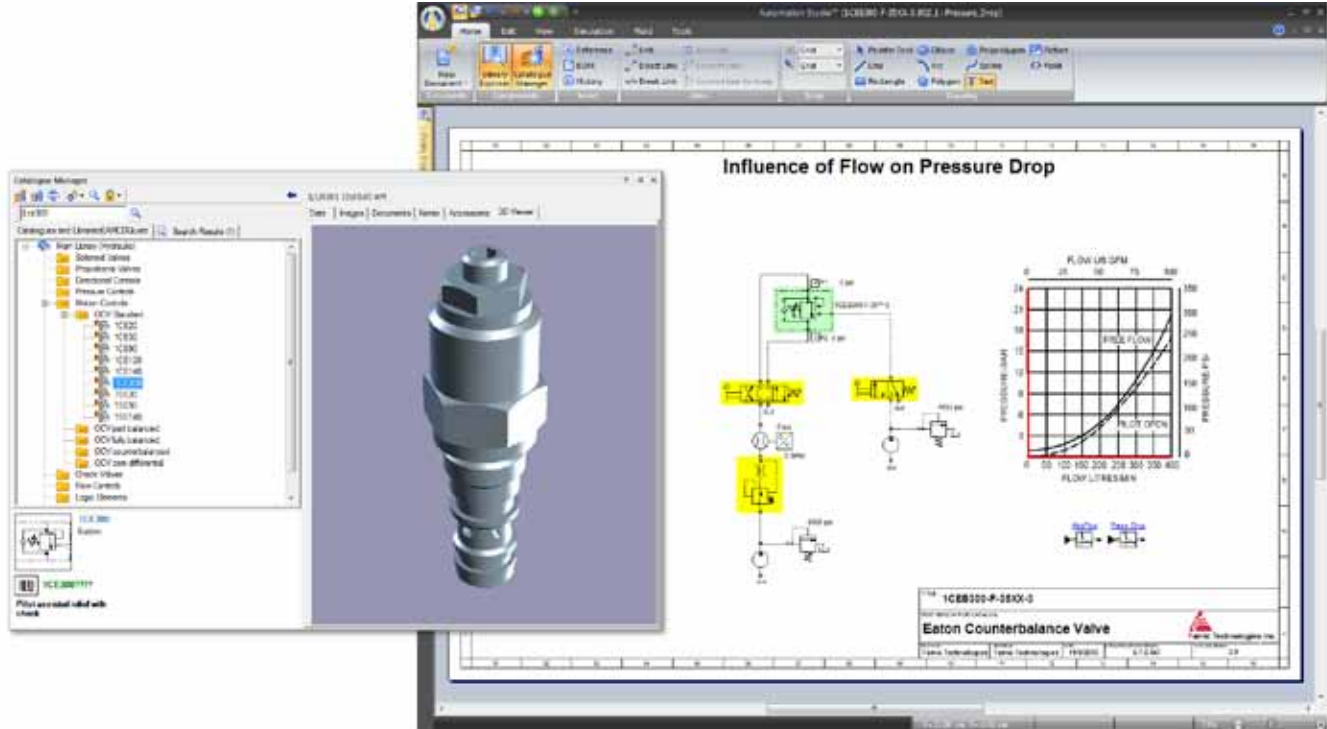

Famic Technologies focuses on customer satisfaction. We have established a strong reputation amongst Fortune 500 companies as well as small OEMs, and we make no compromises to keep it that way. We have a rich pool of specialists to put to work on your needs in order to make the implementation of your solution a success. Whether it is engineering, training, application-specific coaching, or Automation Studio™ customization, we have what it takes to support your organization.

Training

We provide a large array of training sessions. Call us to get more information on our seminars, webinars, on-site and off-site training packages, as well as our consulting services.

Configuration and Catalogues Implementation

Benefit from our expertise to customize your catalogues as per your needs and to integrate them into Automation Studio™.

Broad Expertise for Project Success

Over and above software and system design, our expertise covers many fields in applied industrial engineering including mechanical, electrical, and automation engineering. No matter what your application is, our experts will be there to assist you.

Software Consulting Services

For more than 25 years, Famic Technologies has been participating in strategic systems' development of our customer's operations. Our team has always delivered outstanding performance. We have implemented a rigorous development methodology, which we apply to every project. This structured approach allows all parties involved to participate during every step of the project ensuring that the solution fulfills your exact needs.

Live Online Demonstration

Learn more about Automation Studio™ thanks to a free live online demonstration with one of our specialists. Find out why the top manufacturing companies, as well as construction, mining, forestry, and agricultural OEMs, are using Automation Studio™ more and more for their applications. Contact us now to schedule your demonstration.

Annual Maintenance and Extended Support Plan

Subscribe to our Annual Maintenance Program and take full advantage of the possibilities offered by Automation Studio™. This program grants you exclusive rewards such as an unlimited access to technical support, access to ALL upgrades, and the latest developments of Automation Studio™ as soon as they are available.

Distributed by



A Product of  **25** ans
years
Famic Technologies Inc.

Famic Technologies Inc.
350-9999 Cavendish, Montréal QC, H4M 2X5, Canada
☎ +1 514 748-8050
📠 +1 514 748-7169
🌐 www.automationstudio.com
www.famictech.com

